

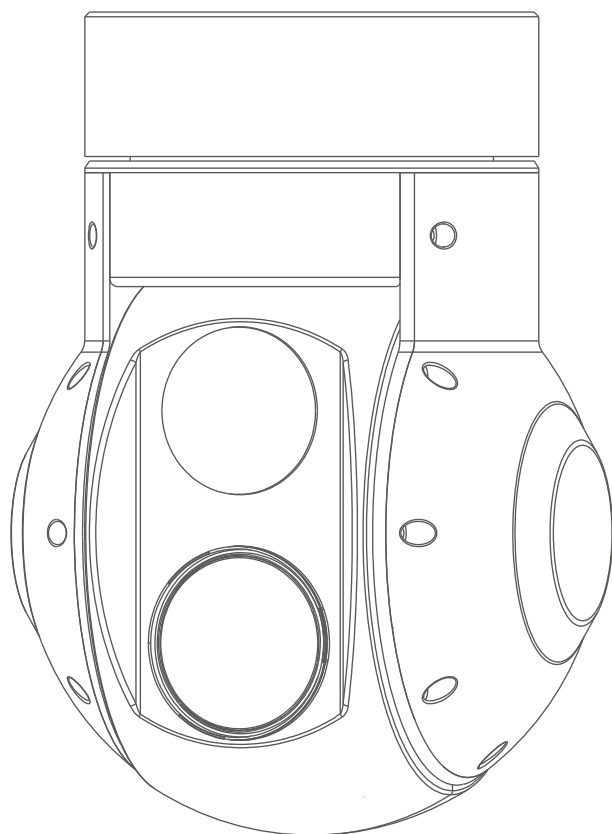

Eagle Eye-30IE-U

30X EO/IR Dual Sensor Zoom Camera



Warning and Disclaimer

Make sure not to adjust the gimbal or change its mechanical structure by yourself. Be sure to mount the camera to gimbal before power on, and then install the gimbal on the aircraft.

To avoid gimbal performance degradation or damage caused by imbalanced payload, please do not add other peripherals for the gimbal camera (filter, hood, etc).

When in aerial photography, make sure your aircraft flight control system is working at the safe mode.

We strongly recommend that you remove aircraft propellers before doing gimbal configuration. Use extra non-power battery for gimbal. Keep children away from the preset flight region.

Considering that we are not able to control user's specific usage, installation, assembly, modification (including the use of non-specified parts), and improper use. Direct or indirect damage or injury caused by the behavior above, our company will not cover any loss and responsibility.

Gimbal description

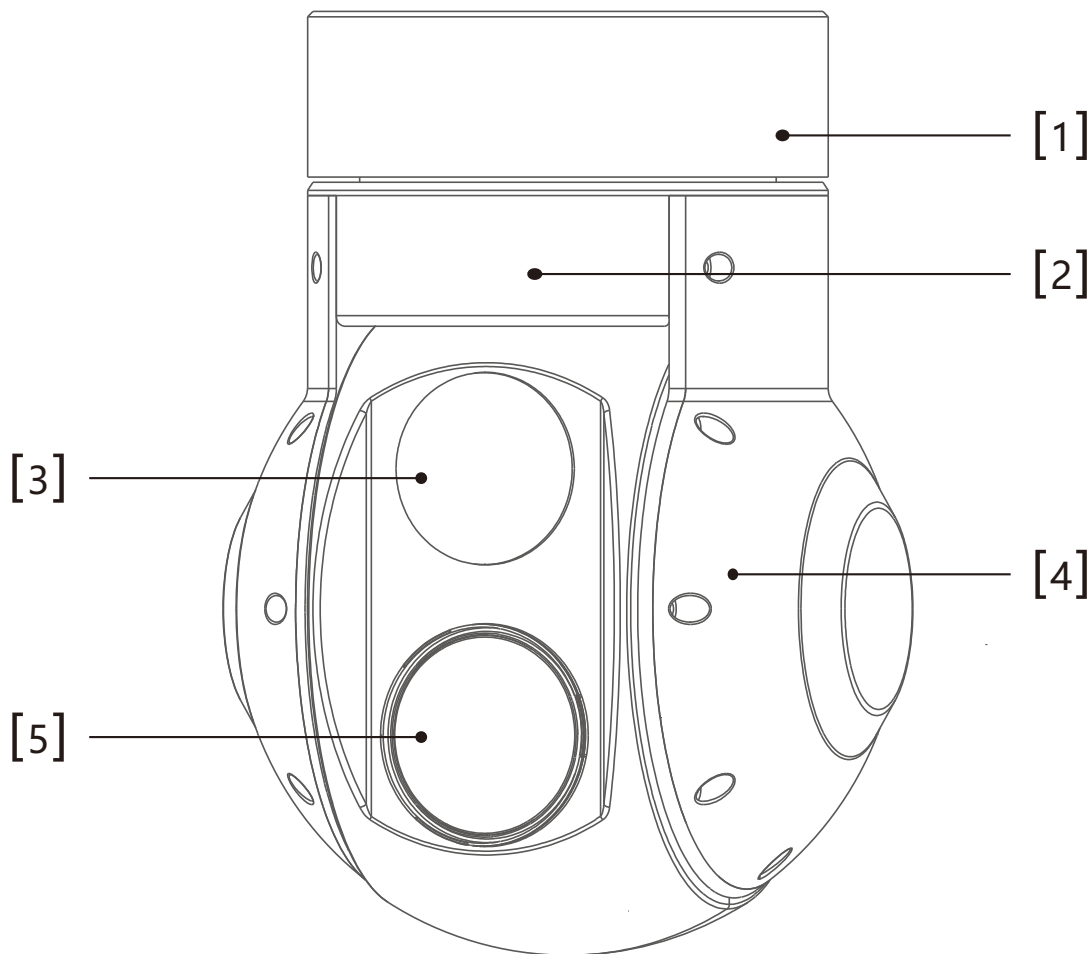

[1] Damping Box

[3] Thermal Camera

[5] Daylight zoom camera

[2] Yaw axis motor

[4] Pitch axis motor



Please make sure that the motor is not stopped by any object during the rotation, if the gimbal is blocked during rotation, please remove the obstruction immediately.

Packing List

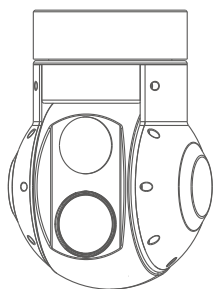

Gimbal camera*1

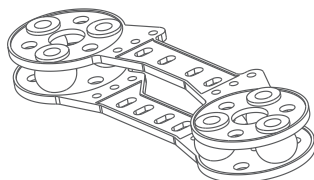

Damping board*2

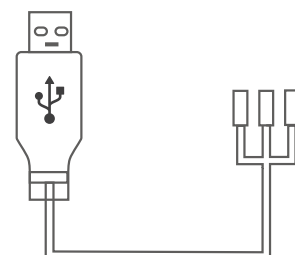

USB to TTL *1

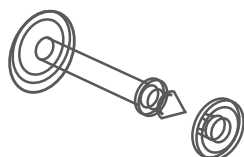

Anti shedding buckle*4



5mm*12

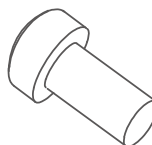

8mm*4

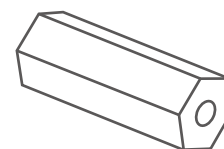

Copper cylinders*4

Gimbal Camera Dimension

Unit : mm

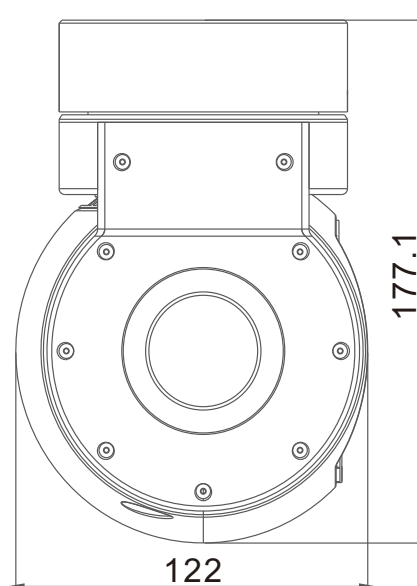
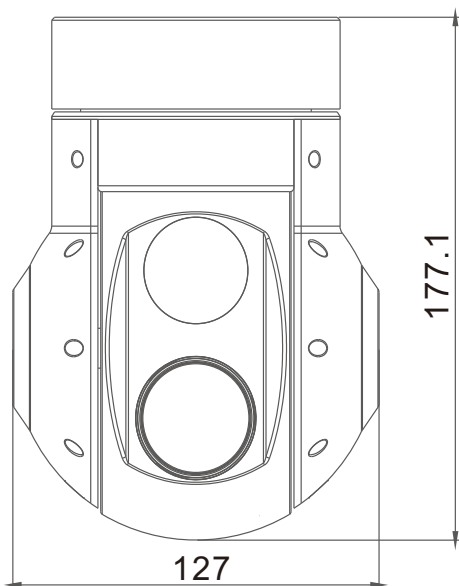

Connection of Control Box and Wiring Instruction

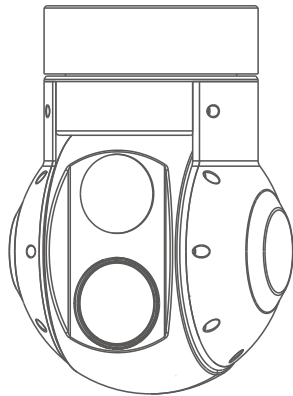

← Control Box position

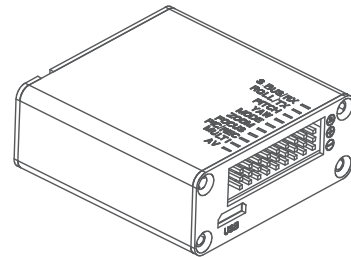

1. Insert SD card

SD card: max 128G, class10
FAT32 or exFAT format

2. Connect HDMI to display

HDMI: micro HDMI OUTPUT
1080P 60fps default

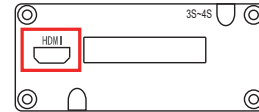

HDMI position

3. Connect the signal line as below

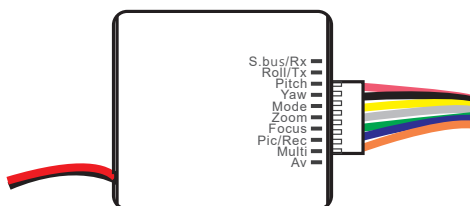
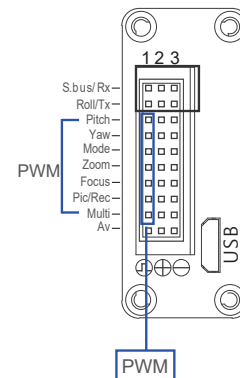
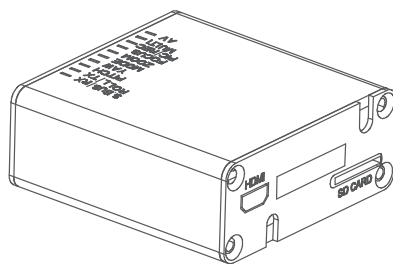

4. Power supply with 12V, red line is positive and black is negative.

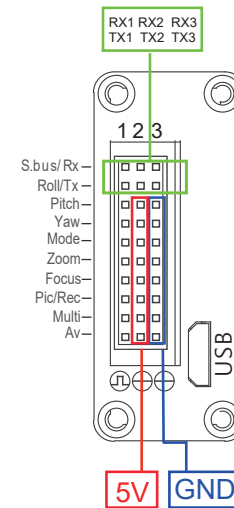
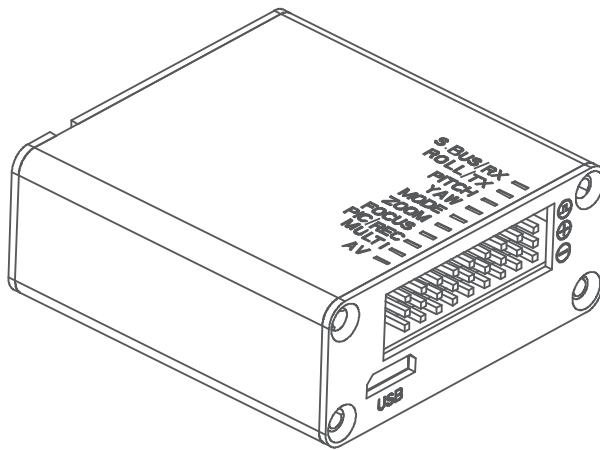

Function Description

Gimbal control

1. Yaw axis control: speed mode, connect Rocker channel (or 3 gears channel, push gear to middle position to stop)
2. Pitch axis control: speed mode, connect Rocker channel (or 3 gears channel, push gear to middle position to stop)
3. Mode control: angle mode, connect knob channel (speed mode: connect 3 gears channel or rocker channel)

If connecting knob channel, rotate to one end, the gimbal is at lowest speed when controlling YAW and PITCH axis.

Rotate the knob to any position, gimbal is at higher speed when controlling YAW and PITCH axis. Rotate to knob to another end, gimbal back to center position.

4 . Multi: tracking control,connect 3 gears channel

- **Middle to low:**quit tracking mode,cursor disappear
- **Low to middle:**go to tracking mode,cursor appear
- **Middle to high:**one square appears,object is locked,tracking is activated
- **Middle to high again:**re-track mode,cursor appears in the square.Gimbal is still tracking the object,now you can move the cursor to track another object(middle to high gear again).

Camera control

1. Zoom control: daylight sensor zoom control, connect 3 gears or rocker channel
2. Focus: Picture in picture switch and palette switch, connect 3 gears channel.
 - Middle to Low: palette switch.
 - Middle to High: picture in picture switch.
3. PIC/REC: taking picture/recording, connect 3 gears channel
 - Middle to high, recording start
 - Middle to high again, recording stop
 - Middle to low, taking picture
 - Middle to low, taking another picture

Signal functions

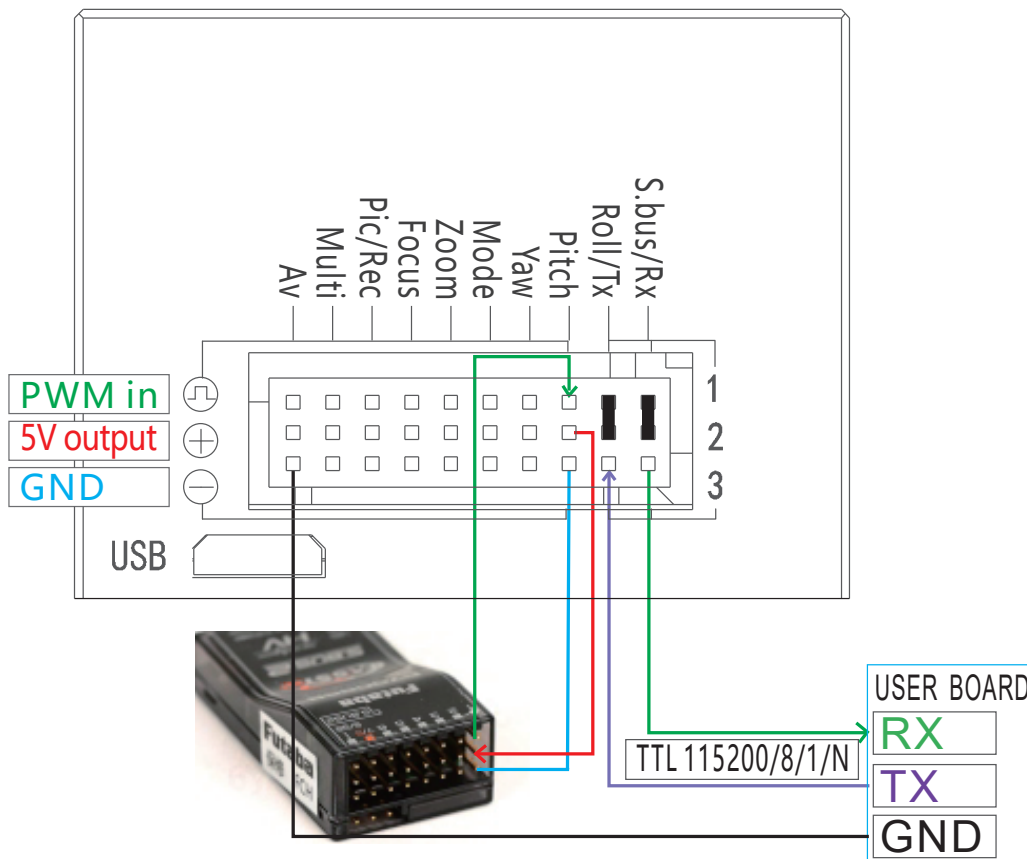

S.bus/Rx: connect to Rx2 for track function.

Roll/ Tx: connect to Tx2 for track function.

Pitch: PWM in, pitch control

Pitch: PWM in, pitch control

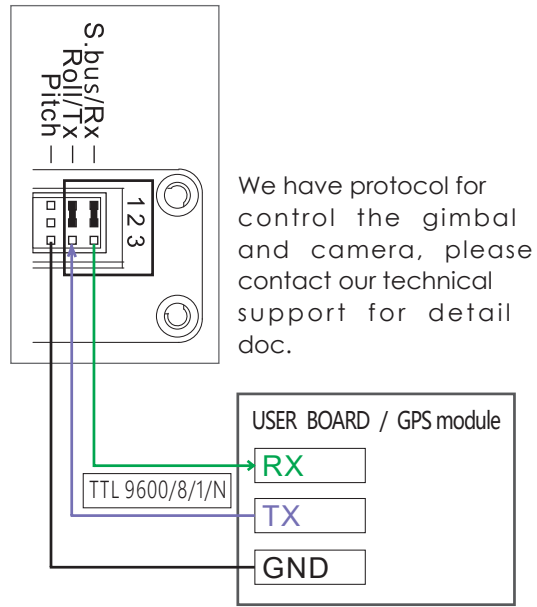
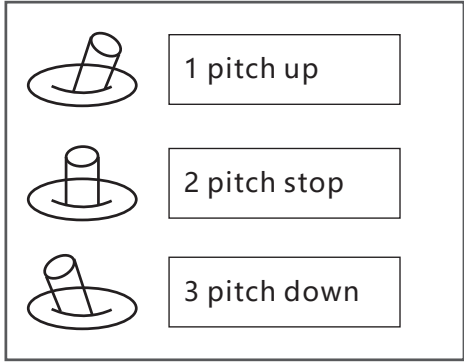

Yaw: PWM in, Yaw contro



Mode: Change the speed / home position

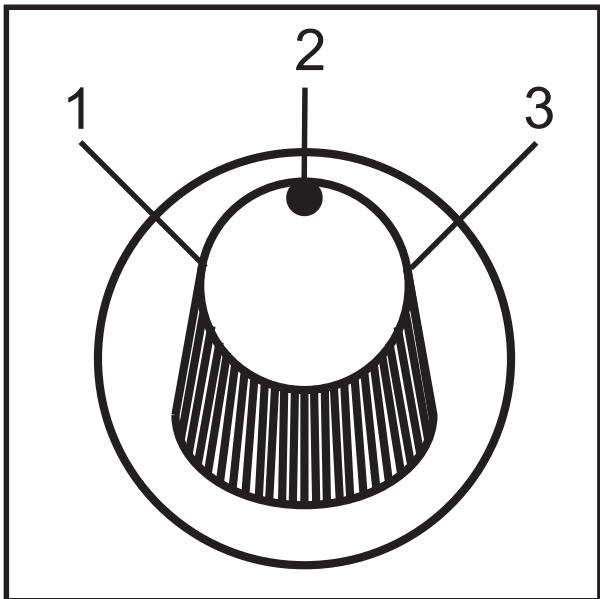

- Position 1: Lowest speed for pitch and yaw.
- Position 2: Middle speed for pitch and yaw.
- Position 3: Highest speed for pitch and yaw.

The speed is continuously quickly from 1 to 3.

- One click: Home position.
- Two click: Look down.
- Three click: Yaw not followed by frame.
- Four click: Yaw followed by frame.
- Five click: Restore the factory settings.

(Click = from 2 to 3 and back to 2 quickly)

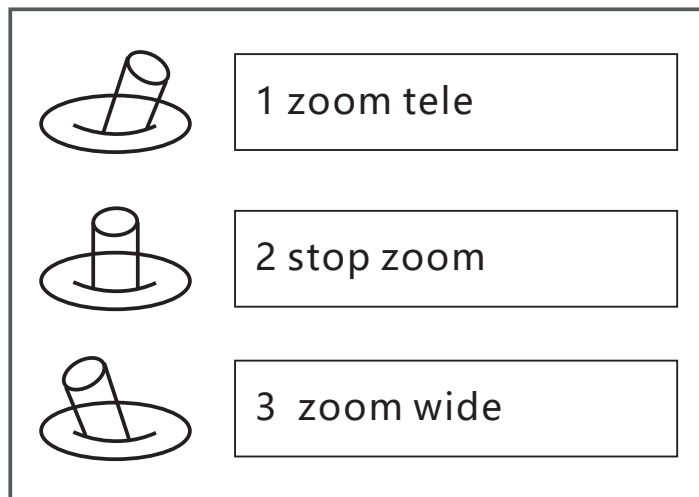
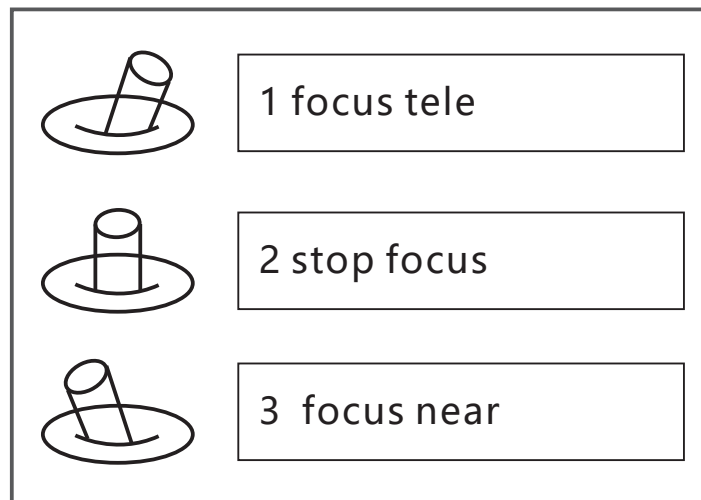
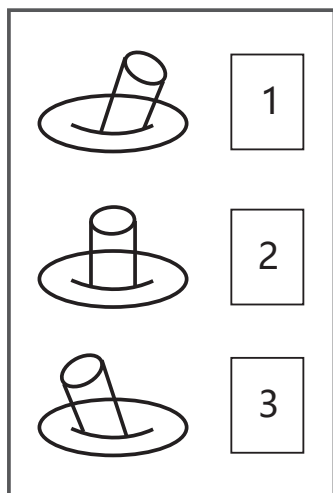
ZOOM: Zoom the camera**Focus: Focus the camera****Pic /Rec picture / Start record, stop record**

1. Position 1 exit the tracking
Switch 1 to 2: Display the cross cursor.
Adjust the object to the cross cursor.
2. Switch 2 to 3: start tracking. Change the object during tracking
Switch 3 to 2: Display the cross cursor, use Pitch/Yaw to adjust the cross cursor.
Switch 2 to 3: Start tracking.

AV: NO AV output

30X zoom camera(SONY FCB EV-7520)	
Sensor	1/2.8 inch 2.13MP CMOS SENSOR
Video output	1080P/60 HDMI, 720P/30 Ethernet
Video recorded	1080P/30 MP4
Focal length	30X optical focal zoom, 4.3-129mm
Digital zoom	12X(360X with optical zoom)
FOV	1080p mode: 63.7°(wide end) ~ 2.3°(tele end)
	720p mode: 63.7°(wide end) ~ 2.3°(tele end)
	SD: 47.8°(wide end) ~ 1.7°(tele end)
Wide Dynamic	Up to 105dB
Auto focus	Less than 1S
Low illumination	0.01lux@F1.6
Aperture	Φ 16.0
Vertical Roll / Horizon Mirror/Static	Support
AWB/AGC/ACC/	Support
Thermal camera	
Lens	25mm
Working system	Un-cooled long wave (8μm~14μm)
Detector pixels	640×480
Pixel size	17μm
Focusing	Athermalizing
FOV	Horizontal: 24.6°
	Vertical: 18.5°
	Diagonal: 30.4°
Detective Distance (Man: 1.8x0.5m)	735 meters
Recognize Distance (Man: 1.8x0.5m)	184 meters
Verified Distance (Man: 1.8x0.5m)	92 meters
Detective Distance (Car: 4.2x1.8m)	2255 meters
Recognize Distance (Car: 4.2x1.8m)	564 meters
Verified Distance (Car: 4.2x1.8m)	282 meters
Emissivity correction	Emissivity 0.01~1 adjustable
NETD	≤50mK(@25°C)
MRTD	≤650mK(@Characteristic frequency)
Image enhancement	Automatically adjusts image brightness and contrast
Color palette	White hot, pseudo color
Automatic non-uniformity correctionfunction	Yes(with or without shutter)
Digital zoom	1x, 2x, 3x, and 4x
Time synchronization function	Yes
Gimbal system	
Input voltage	3S-4S
Rotate range	Pitch: ±90° Yaw: unlimited
Angle amount of jitter	Pitch: ±0.02° Yaw:±0.03°
Control interface	PWM, S.Bus, serial command and software control via Ethernet
Working Current	Static current: 330mA(@12V) Dynamic current: 450mA(@12V)
Mechanical feature	
Total weight (gimbal and camera)	1200g
Working temperature	-25° ~ +60°